

# Игольчатые вентили серии VNA

## Техническое описание.

### По вопросам продаж и поддержки обращайтесь:

Архангельск +7 (8182) 45-71-35  
Астана +7 (7172) 69-68-15  
Астрахань +7 (8512) 99-46-80  
Барнаул +7 (3852) 37-96-76  
Белгород +7 (4722) 20-58-80  
Брянск +7 (4832) 32-17-25  
Владивосток +7 (4232) 49-26-85  
Владимир +7 (4922) 49-51-33  
Волгоград +7 (8442) 45-94-42  
Воронеж +7 (4732) 12-26-70  
Екатеринбург +7 (343) 302-14-75  
Иваново +7 (4932) 70-02-95  
Ижевск +7 (3412) 20-90-75  
Иркутск +7 (3952) 56-24-09  
Йошкар-Ола +7 (8362) 38-66-61  
Казань +7 (843) 207-19-05

Калининград +7 (4012) 72-21-36  
Калуга +7 (4842) 33-35-03  
Кемерово +7 (3842) 21-56-70  
Киров +7 (8332) 20-58-70  
Краснодар +7 (861) 238-86-59  
Красноярск +7 (391) 989-82-67  
Курск +7 (4712) 23-80-45  
Липецк +7 (4742) 20-01-75  
Магнитогорск +7 (3519) 51-02-81  
Москва +7 (499) 404-24-72  
Мурманск +7 (8152) 65-52-70  
Наб.Челны +7 (8552) 91-01-32  
Ниж.Новгород +7 (831) 200-34-65  
Нижневартовск +7 (3466) 48-22-23  
Нижнекамск +7 (8555) 24-47-85

Новороссийск +7 (8617) 30-82-64  
Новосибирск +7 (383) 235-95-48  
Омск +7 (381) 299-16-70  
Орел +7 (4862) 22-23-86  
Оренбург +7 (3532) 48-64-35  
Пенза +7 (8412) 23-52-98  
Первоуральск +7 (3439) 26-01-18  
Пермь +7 (342) 233-81-65  
Ростов-на-Дону +7 (863) 309-14-65  
Рязань +7 (4912) 77-61-95  
Самара +7 (846) 219-28-25  
Санкт-Петербург +7 (812) 660-57-09  
Саранск +7 (8342) 22-95-16  
Саратов +7 (845) 239-86-35  
Смоленск +7 (4812) 51-55-32

Сочи +7 (862) 279-22-65  
Ставрополь +7 (8652) 57-76-63  
Сургут +7 (3462) 77-96-35  
Сызрань +7 (8464) 33-50-64  
Сыктывкар +7 (8212) 28-83-02  
Тверь +7 (4822) 39-50-56  
Томск +7 (3822) 48-95-05  
Тула +7 (4872) 44-05-30  
Тюмень +7 (3452) 56-94-75  
Ульяновск +7 (8422) 42-51-95  
Уфа +7 (347) 258-82-65  
Хабаровск +7 (421) 292-95-69  
Чебоксары +7 (8352) 28-50-89  
Челябинск +7 (351) 277-89-65  
Череповец +7 (8202) 49-07-18  
Ярославль +7 (4852) 67-02-35

сайт: [aflow.pro-solution.ru](http://aflow.pro-solution.ru) | эл. почта: [awf@pro-solution.ru](mailto:awf@pro-solution.ru)  
телефон: 8 800 511 88 70

# INTEGRAL BONNET NEEDLE VALVES. VNA SERIES

## I. FEATURES

- Compact design
- Low operating torques
- Panel mounting
- Variety of stem tips
- Variety of End Connections
- Straight and Angle flow patterns
- Each valve is tested at the factory

## II. SPECIFICATIONS

Pressure rating	345 bar (5000psig) @ 38°C (100°F)
Temperature rating	-54 to 232°C (-65 to 450°F) with PTFE packing and 315°C (600°F) with PEEK packing
Body material	316 stainless steel, alloy 400 and brass
Orifice	2.0 mm to 9.5 mm (0.08" to 0.375")

## III. TESTING

Each Valve is tested with nitrogen at 69 bar (1000 psig) to maximum allowable leak rate of 0.1 SCCM.

## IV. MATERIALS OF CONSTRUCTION

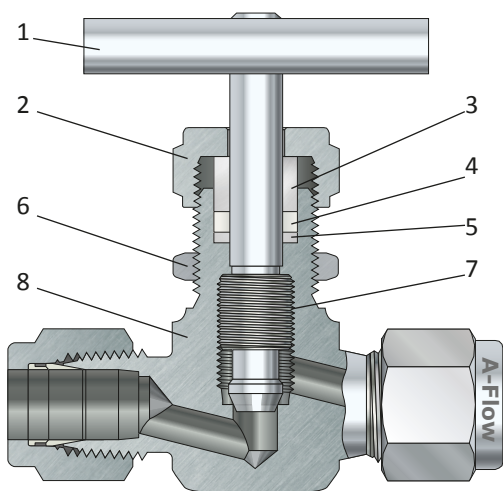

No.	Component	Material Grade / ASTM Specification		
		Stainless Steel	Brass	Alloy 400
1	Bar Handle	Stainless Steel		
	Knob Handle	Phenolic with brass insert		
	Set Screw	Stainless Steel		
2	Packing Nut	SS316 / A276	BRASS 360 / B16	Alloy R-405 / B164
3	Packing Gland	SS316 / A276	BRASS 360 / B16	Alloy R-405 / B164
*4	Packing	PTFE (Standard) , PEEK (Optional)		
5	Packing Support	SS316 / A276	BRASS 360 / B16	Alloy R-405 / B164
6	Panel Nut	SS316 / A276	BRASS 360 / B16	Alloy R-405 / B164
*7	Vee Stem	SS316 / A276	SS316 / A276	Alloy R-405 / B164
	Regulating Stem			
	Soft Seat Stem with PCTFE			
*8	Body	SS 316 / A182	BRASS 377 / B283	Alloy R-400 / B564

•Wetted components are marked "\*"

## HANDLE

- Stainless steel bar is standard on all SS and alloy 400 body valves.
- Black phenolic knob is standard for brass body and soft seat stem valves.
- Black aluminum bar handles are available as an option.

## AVAILABLE STEM TYPE

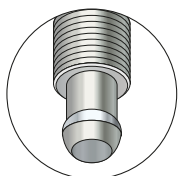

Vee Stem(Standard)

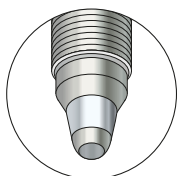

Regulating Stem

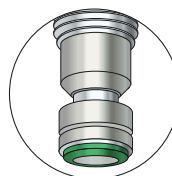

Soft Seat Stem

## FLOW COEFFICIENT (CV) VS NUMBER OF HANDLE TURNS

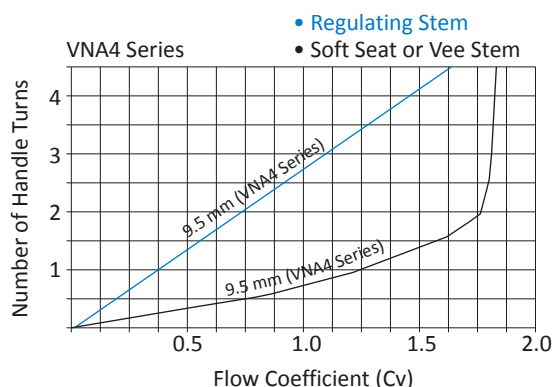
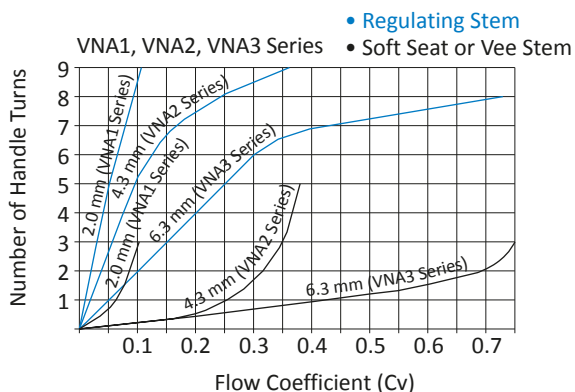

V. TABLE OF DIMENSIONS

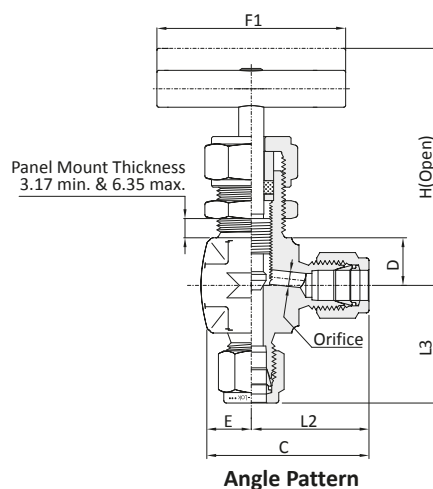
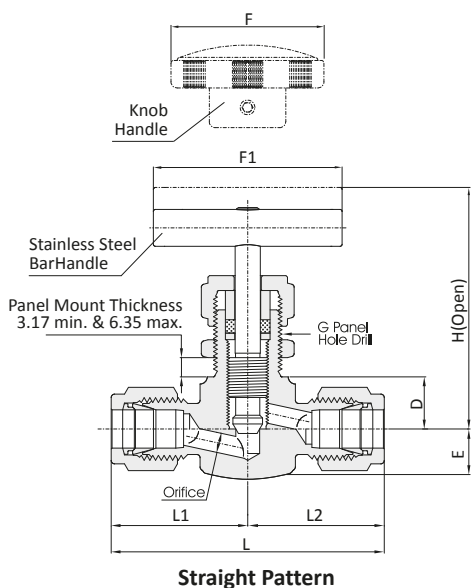

Order Number			Orifice (mm)	Cv	End Connections		Dimensions (mm)														
Series	Part No.	Inlet			Outlet	L	A	B	B1	C	D	E	F	I	H						
VNA1	F	2N	2.0	0.09	1/8" Female NPT		47.8	23.9	23.9	23.9	31.8	11.2	7.9	32.0	11.9	55.0					
	M	2N			1/8" Male NPT		38.1	19.1	19.1	19.1	27.0										
	MA	2N-2			1/8" Male NPT	1/8" A-Flok	43.8										24.7	24.7	32.6		
	A	2T			1/8" A-Flok		49.4														
	A	3M			3mm A-Flok																
VNA2	F	2N	4.4	0.37	1/8" Female NPT		41.2	20.6	20.6	20.6	30.3	11.2	9.7	45.0	13.5	51.5					
	M	2N			1/8" Male NPT		49.8	24.9	24.9	34.6											
	MA	4N-4T			1/4" Male NPT	1/4" A-Flok	53.6				28.7						28.7	38.4			
	A	6M			6mm A-Flok		57.4														
	A	4T			1/4" A-Flok																
	A	8M			8mm A-Flok		59.4	29.7	29.7	29.7	39.4										
	VNA3	F			4N	6.3	0.73	1/4" Female NPT		53.8	26.9						26.9	26.9	39.6	12.7	
F		4R	1/4" ISO Female																		
MF		4N	1/4" Male NPT	1/4" Female NPT	55.6			28.7	28.7	28.7	41.4										
MA		4N-6	1/4" Male NPT	3/8" A-Flok	61.5							32.8	32.8	45.5							
M		6N	3/8" Male NPT		57.4																
MA		6N-6T	3/8" Male NPT	3/8" A-Flok	61.5			35.6	35.6	48.3	14.2										
MA		6N-8T	3/8" Male NPT	1/2" A-Flok	64.3																
A		10M	10mm A-Flok		66.0							33.0	33.0	33.0	45.7						
A		6T	3/8" A-Flok		65.6			32.8	32.8	32.8	45.5	12.7									
A		12M	12 mm A-Flok		71.2			35.6	35.6	35.6	48.3		14.0								
A		8T	1/2" A-Flok																		
VNA4	F	6N	9.5	1.80	3/8" Female NPT		76.2	38.1	38.1	38.1	57.2	19.1	19.1	76.0	26.2	99.5					
	F	6R			3/8" ISO Female																
	F	8N			1/2" Female NPT																
	F	8R			1/2" ISO Female																
	M	8N			1/2" Male NPT																
	MF	8N			1/2" Male NPT	1/2" Female NPT															
	A	8T			1/2" A-Flok												96.6	48.3	48.3	48.3	67.4
	A	12T			3/4" A-Flok																

\* Dimensions shown with A-Flok nuts measure in the finger - tight, where applicable. All dimensions are for reference only, subject to change.

## VI. TECHNICAL DATA

### TEMPERATURE AND PRESSURE RATING

Body Material	Stem	Pressure Rating	Pressure Rating @ -54°C to 38°C (-65°F to 100°F)
SS316	Vee & Regulating	-54°C to 232°C (-65°F to 450°F)	345 bar (5000 psig)
	Soft Seat	-54°C to 93°C (-65°F to 200°F)	
Brass	Vee & Regulating	-54°C ~204°C (-65°F to 400°F)	207 bar (3000 psig)
	Soft Seat	-54°C to 93°C (-65°F to 200°F)	
Alloy 400 (Monel)	Vee & Regulating	-54°C to 232°C (-65°F to 450°F)	207 bar (3000 psig)
	Soft Seat	-54°C to 93°C (-65°F to 200°F)	

\* The above ratings are for a standard valve with PTFE packing. \* Extreme temperature fluctuations may require packing adjustment.

### TEMPERATURE VS WORKING PRESSURE

Temperature Rating		Pressure psig(bar) @ Temperature Rating		
		SS316	Brass	Alloy 400 (Monel)
-54°C (-65°F)	38°C (100°F)	345 bar (5000 psig)	207 bar (3000 psig)	207 bar (3000 psig)
	93°C (200°F)	296 bar (4290 psig)	179 bar (2600 psig)	182 bar (2640 psig)
	148°C (300°F)	267 bar (3870 psig)	152 bar (2210 psig)	170 bar (2470 psig)
	176°C (350°F)	256 bar (3710 psig)	101 bar (1470 psig)	167 bar (2430 psig)
	204°C (400°F)	245 bar (3560 psig)	51 bar (740 psig)	165 bar (2390 psig)
	232°C (450°F)	236 bar (3430 psig)	-	163 bar (2380 psig)

### PACKING AND BODY MATERIALS VS TEMPERATURE AND PRESSURE RATING

Packing Material	Body Material	Temperature Rating	Pressure Rating @ Max. Temperature
PTFE (Standard)	SS316	-54°C to 232°C (-65°F to 450°F)	236 bar (3430 psig)
PEEK (Optional)	SS316	-54°C to 315°C (-65°F to 600°F)	216 bar (3130 psig)
	Alloy 400	-54°C to 260°C (-65°F to 500°F)	163 bar (2370 psig)

\* PEEK is not recommended for service with aromatic heat transfer or concentrated sulfuric and nitric acids. Other limitations may apply.

## VII. ORDERING INFORMATION

**VNA3 - L - MA - 6N 8T - PK - RT - KH - SS**

**Valve Series**  
 "VNA1" – 2.0mm Orifice  
 "VNA2" – 4.4mm Orifice  
 "VNA3" – 6.3mm Orifice  
 "VNA4" – 9.5mm Orifice

**Flow Pattern**  
 "-" – Straight Pattern (Standard)  
 "L" – Angle Pattern

**Port Type**  
 "A" – A-Flok Tube Fitting  
 "M" – Male Pipe Thread  
 "F" – Female Pipe Thread  
 "MA" – Male Pipe Thread x A-Flok Tube Fitting  
 "MF" – Male Pipe Thread x Female Pipe Thread

Inlet    Outlet

**Body Material**  
 "SS" – 316 Stainless Steel  
 "BR" – Brass  
 "MO" – Alloy 400 (Monel)

**Handle**  
 "-" – Stainless Steel Bar Handle (Standard)  
 "KH" – Phenolic Knob Handle

**Stem Type**  
 "-" – Vee Stem (Standard)  
 "RT" – Regulating Stem  
 "ST" – Soft Seat Stem

**Packing Material**  
 "-" – PTFE (Standard)  
 "PK" – PEEK

**Port Size**

Pipe Thread Designation

Size (inch)	1/8	1/4	3/8	1/2	3/4
Screwed BSPT	2R	4R	6R	8R	12R
Screwed NPT	2N	4N	6N	8N	12N

Tube O.D Designation

Tube O.D (inch)	1/8	1/4	3/8	1/2	3/4
Designation	2	4	6	8	12
Tube O.D (mm)	3	6	8	10	12
Designation	3M	6M	8M	10M	12M

## По вопросам продаж и поддержки обращайтесь:

Архангельск +7 (8182) 45-71-35  
Астана +7 (7172) 69-68-15  
Астрахань +7 (8512) 99-46-80  
Барнаул +7 (3852) 37-96-76  
Белгород +7 (4722) 20-58-80  
Брянск +7 (4832) 32-17-25  
Владивосток +7 (4232) 49-26-85  
Владимир +7 (4922) 49-51-33  
Волгоград +7 (8442) 45-94-42  
Воронеж +7 (4732) 12-26-70  
Екатеринбург +7 (343) 302-14-75  
Иваново +7 (4932) 70-02-95  
Ижевск +7 (3412) 20-90-75  
Иркутск +7 (3952) 56-24-09  
Йошкар-Ола +7 (8362) 38-66-61  
Казань +7 (843) 207-19-05

Калининград +7 (4012) 72-21-36  
Калуга +7 (4842) 33-35-03  
Кемерово +7 (3842) 21-56-70  
Киров +7 (8332) 20-58-70  
Краснодар +7 (861) 238-86-59  
Красноярск +7 (391) 989-82-67  
Курск +7 (4712) 23-80-45  
Липецк +7 (4742) 20-01-75  
Магнитогорск +7 (3519) 51-02-81  
Москва +7 (499) 404-24-72  
Мурманск +7 (8152) 65-52-70  
Наб.Челны +7 (8552) 91-01-32  
Ниж.Новгород +7 (831) 200-34-65  
Нижневартовск +7 (3466) 48-22-23  
Нижнекамск +7 (8555) 24-47-85

Новороссийск +7 (8617) 30-82-64  
Новосибирск +7 (383) 235-95-48  
Омск +7 (381) 299-16-70  
Орел +7 (4862) 22-23-86  
Оренбург +7 (3532) 48-64-35  
Пенза +7 (8412) 23-52-98  
Первоуральск +7 (3439) 26-01-18  
Пермь +7 (342) 233-81-65  
Ростов-на-Дону +7 (863) 309-14-65  
Рязань +7 (4912) 77-61-95  
Самара +7 (846) 219-28-25  
Санкт-Петербург +7 (812) 660-57-09  
Саранск +7 (8342) 22-95-16  
Саратов +7 (845) 239-86-35  
Смоленск +7 (4812) 51-55-32

Сочи +7 (862) 279-22-65  
Ставрополь +7 (8652) 57-76-63  
Сургут +7 (3462) 77-96-35  
Сызрань +7 (8464) 33-50-64  
Сыктывкар +7 (8212) 28-83-02  
Тверь +7 (4822) 39-50-56  
Томск +7 (3822) 48-95-05  
Тула +7 (4872) 44-05-30  
Тюмень +7 (3452) 56-94-75  
Ульяновск +7 (8422) 42-51-95  
Уфа +7 (347) 258-82-65  
Хабаровск +7 (421) 292-95-69  
Чебоксары +7 (8352) 28-50-89  
Челябинск +7 (351) 277-89-65  
Череповец +7 (8202) 49-07-18  
Ярославль +7 (4852) 67-02-35

сайт: [aflow.pro-solution.ru](http://aflow.pro-solution.ru) | эл. почта: [awf@pro-solution.ru](mailto:awf@pro-solution.ru)  
телефон: 8 800 511 88 70